

D5000
KAT00F00RA-D466
A1 COMBO 32MX32 DDR
128MX16 M3

BOOT configuration,
1010=boot from 16-bit MuxedOneNAND

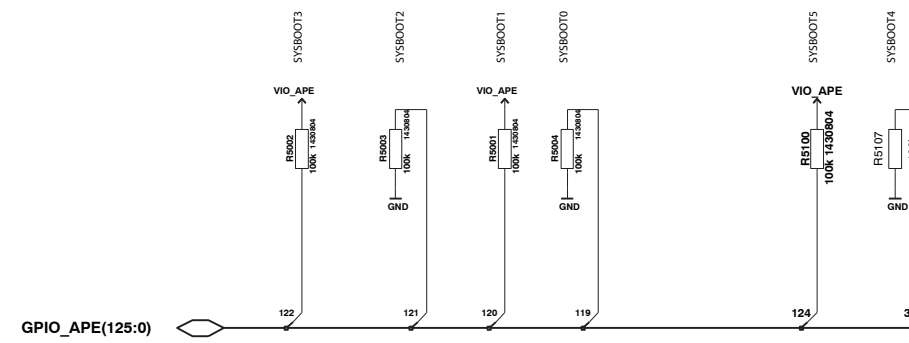

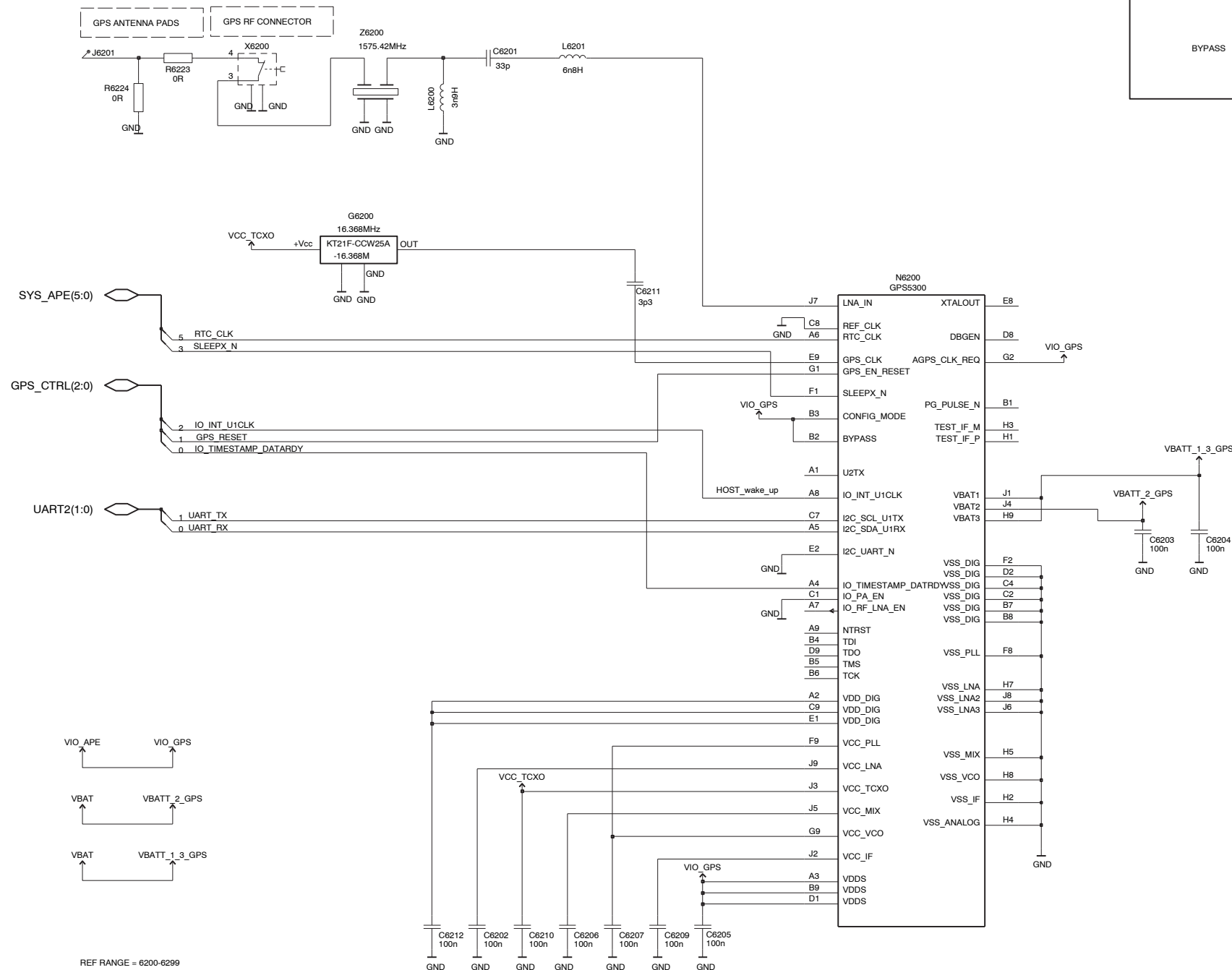

PIN	CONNECT TO	
	VIO_GPS	GND
I2C_UART_N	I2C MODE	UART MODE
BYPASS	CLOCK SLICER BYPASSED MODE [REF_CLK IS DIGITAL]	CLOCK SLICER ENABLED MODE [REF_CLK IS ANALOG]

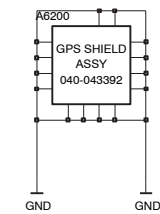

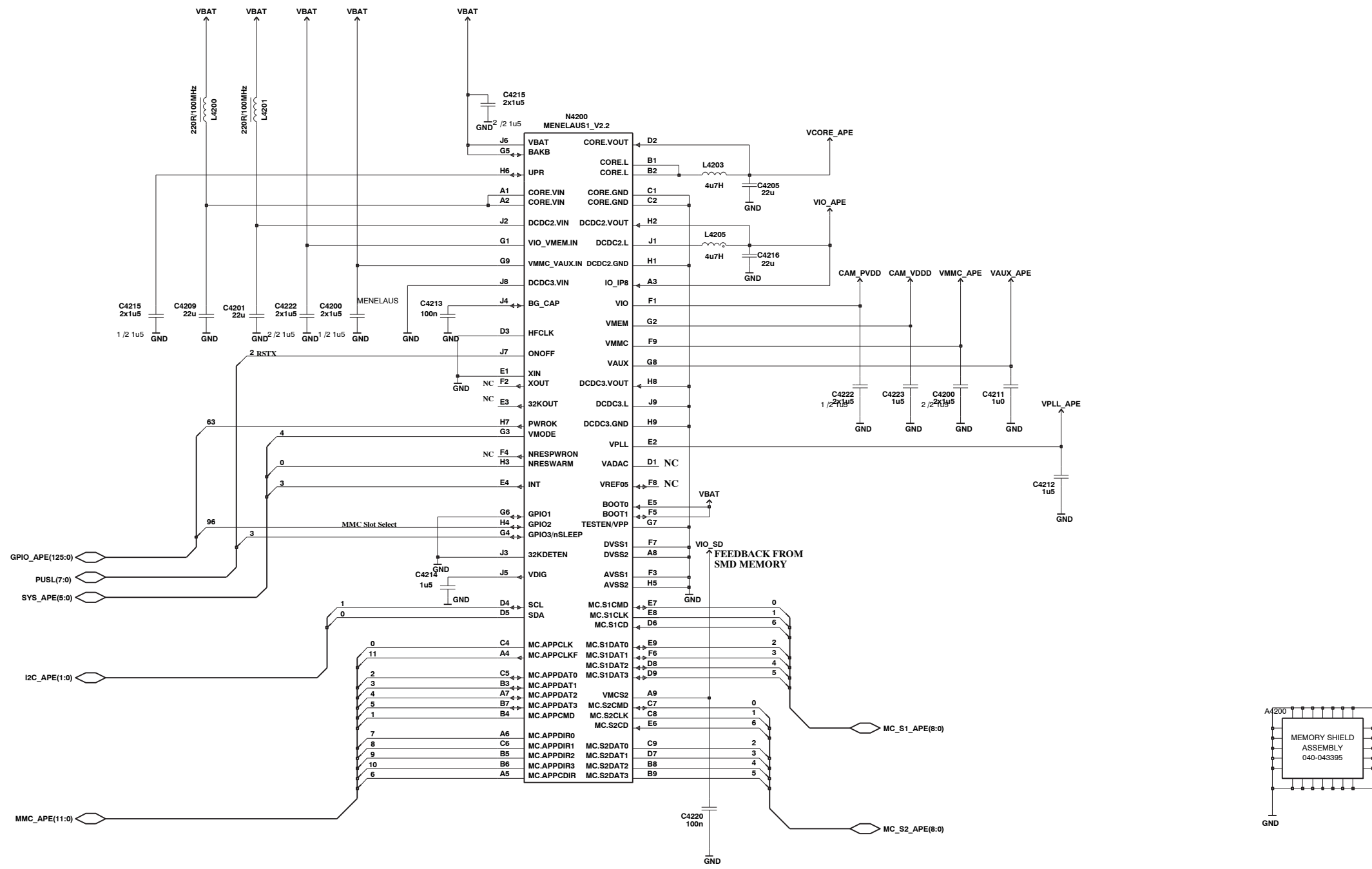

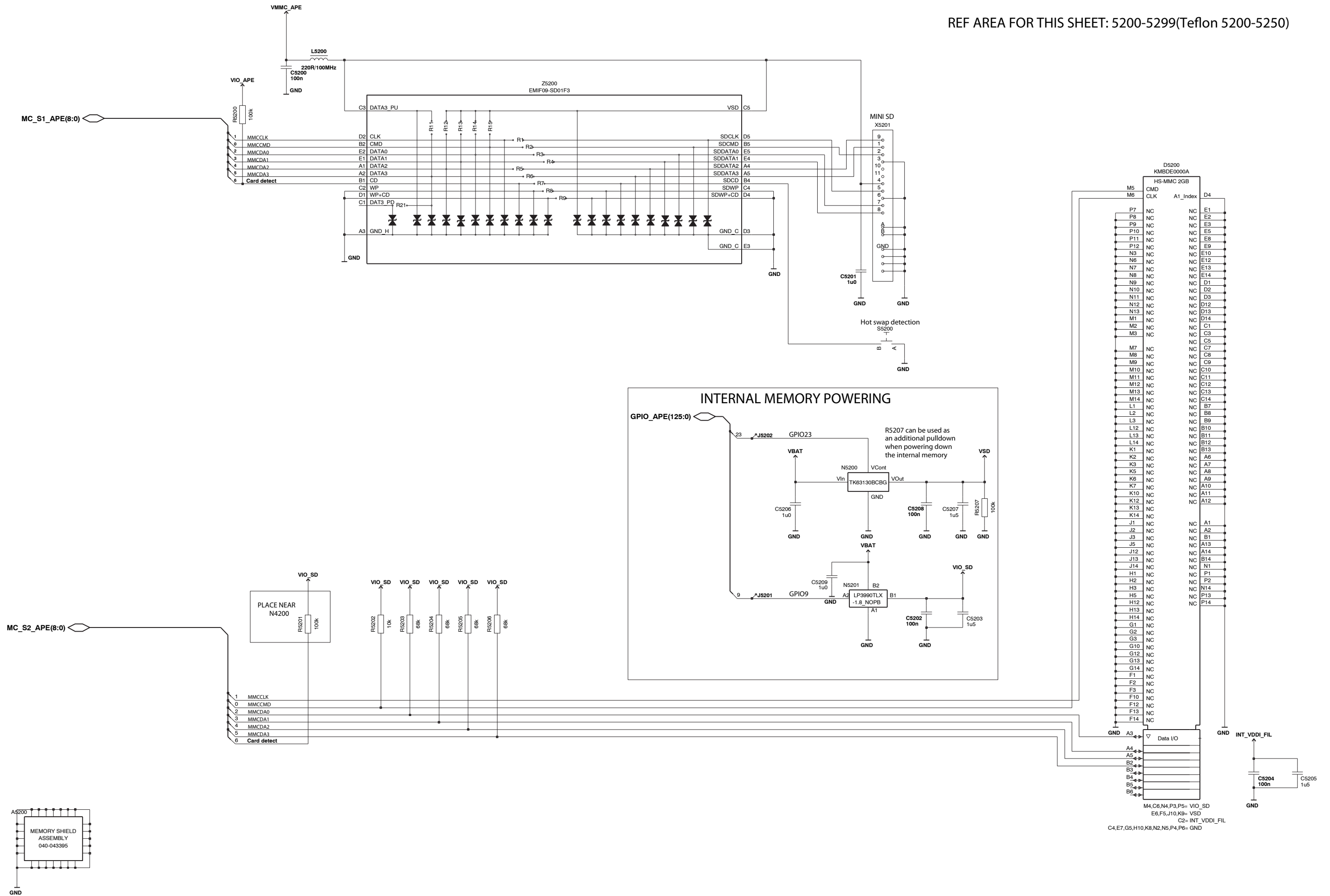

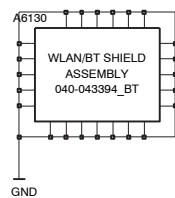
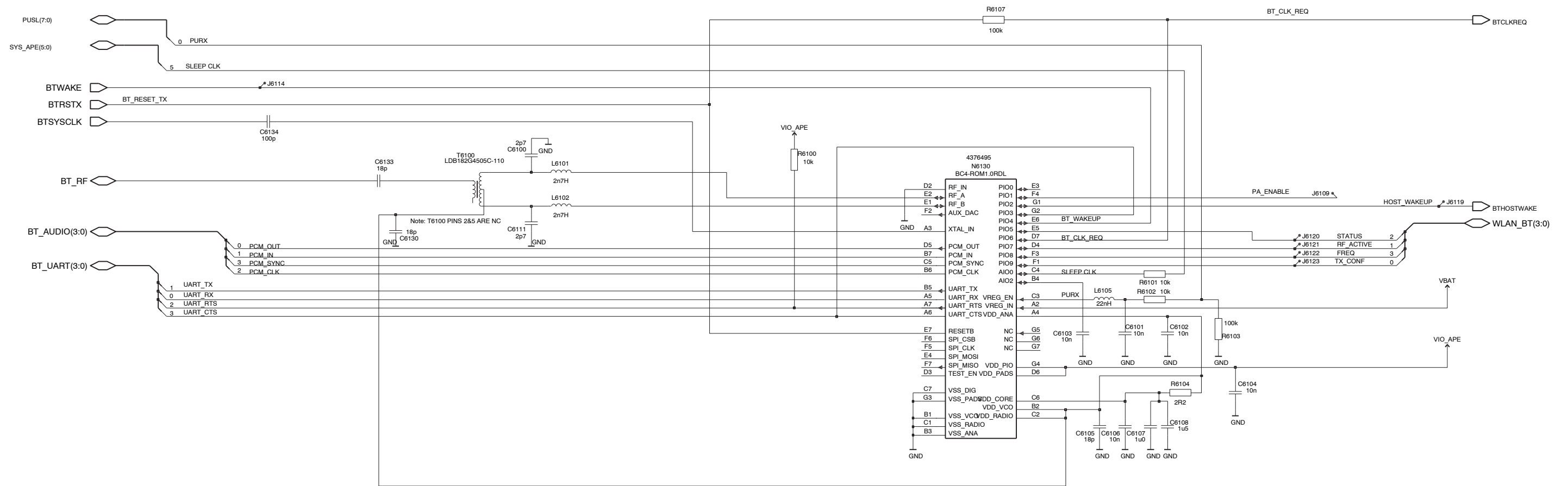

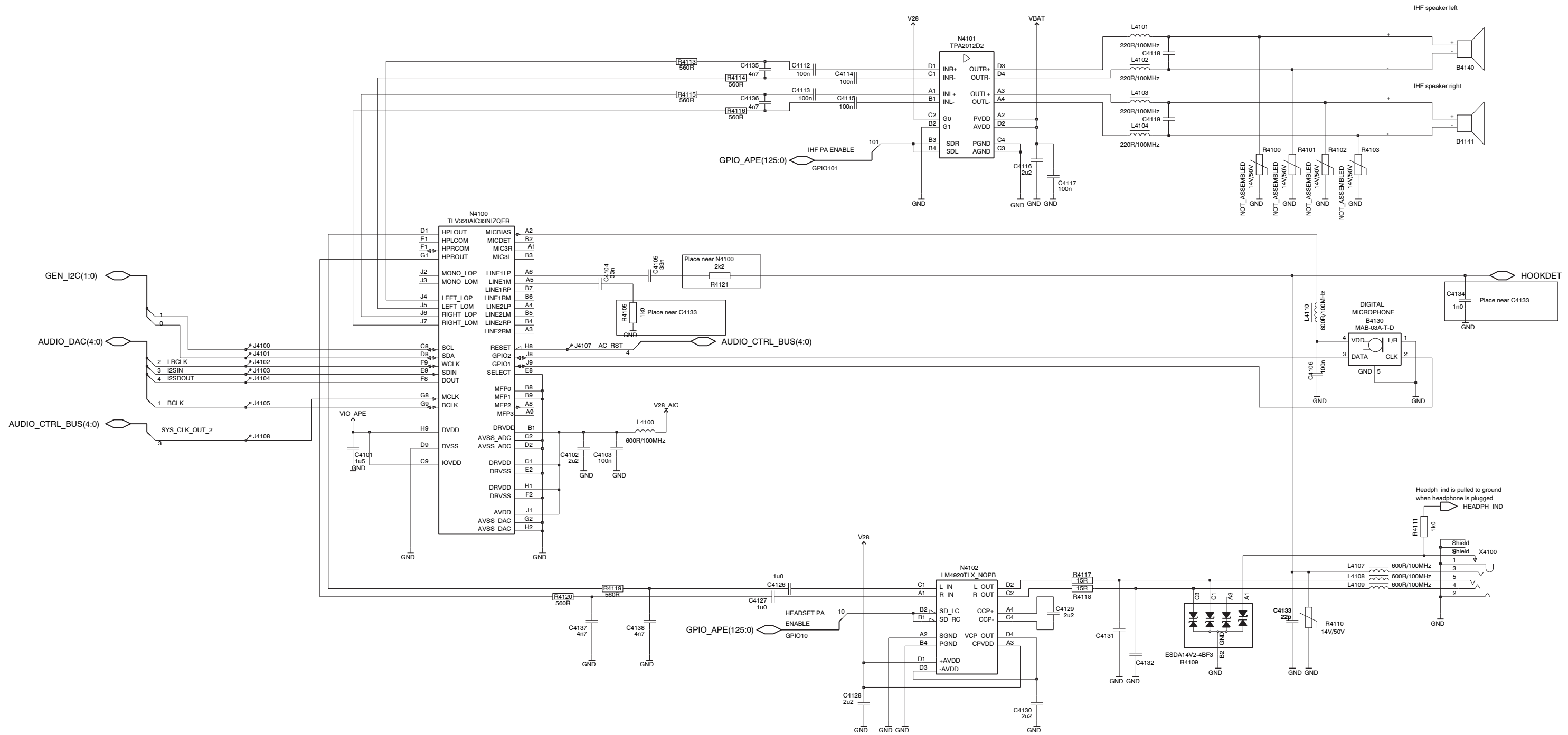

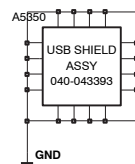
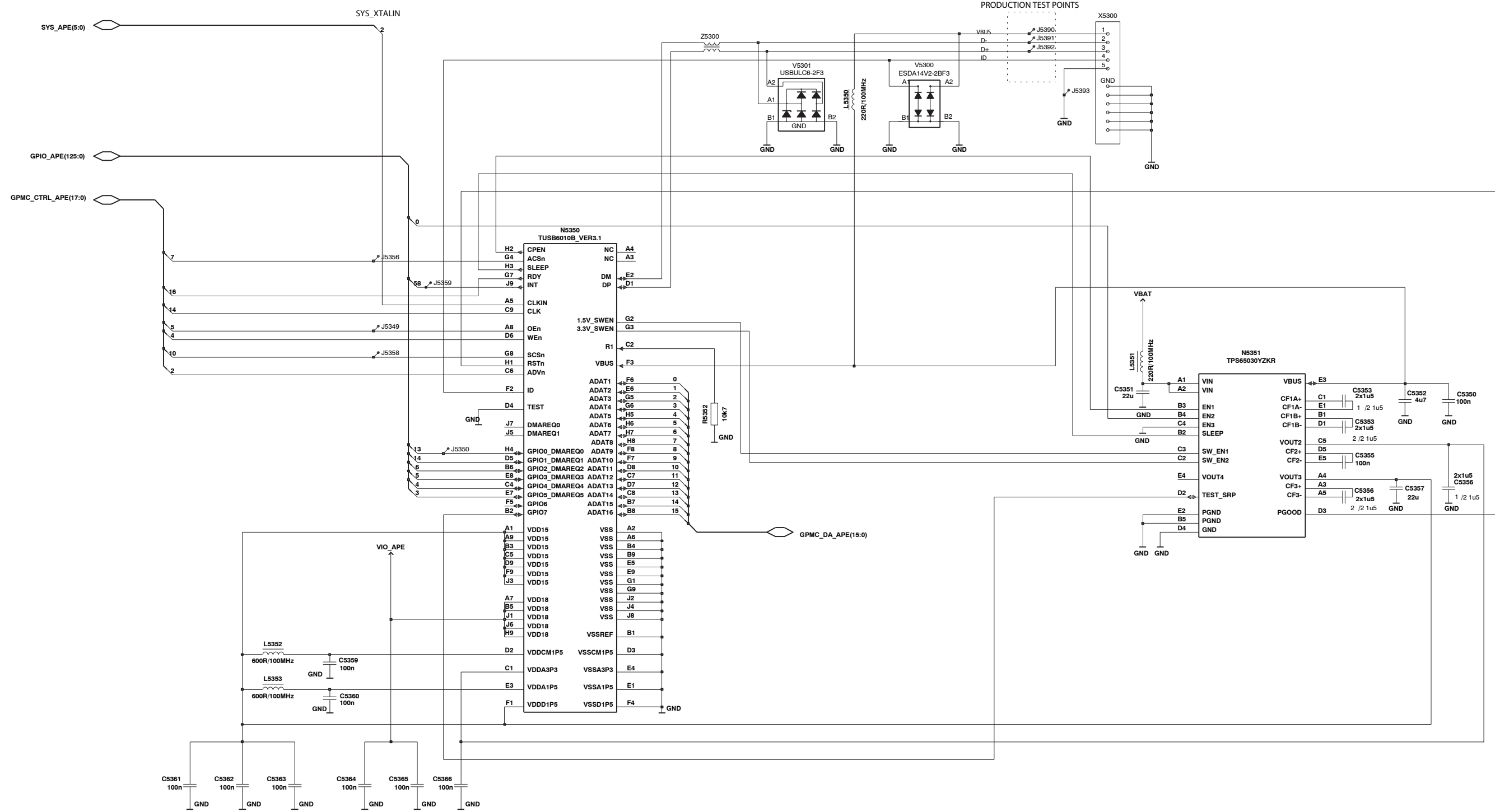

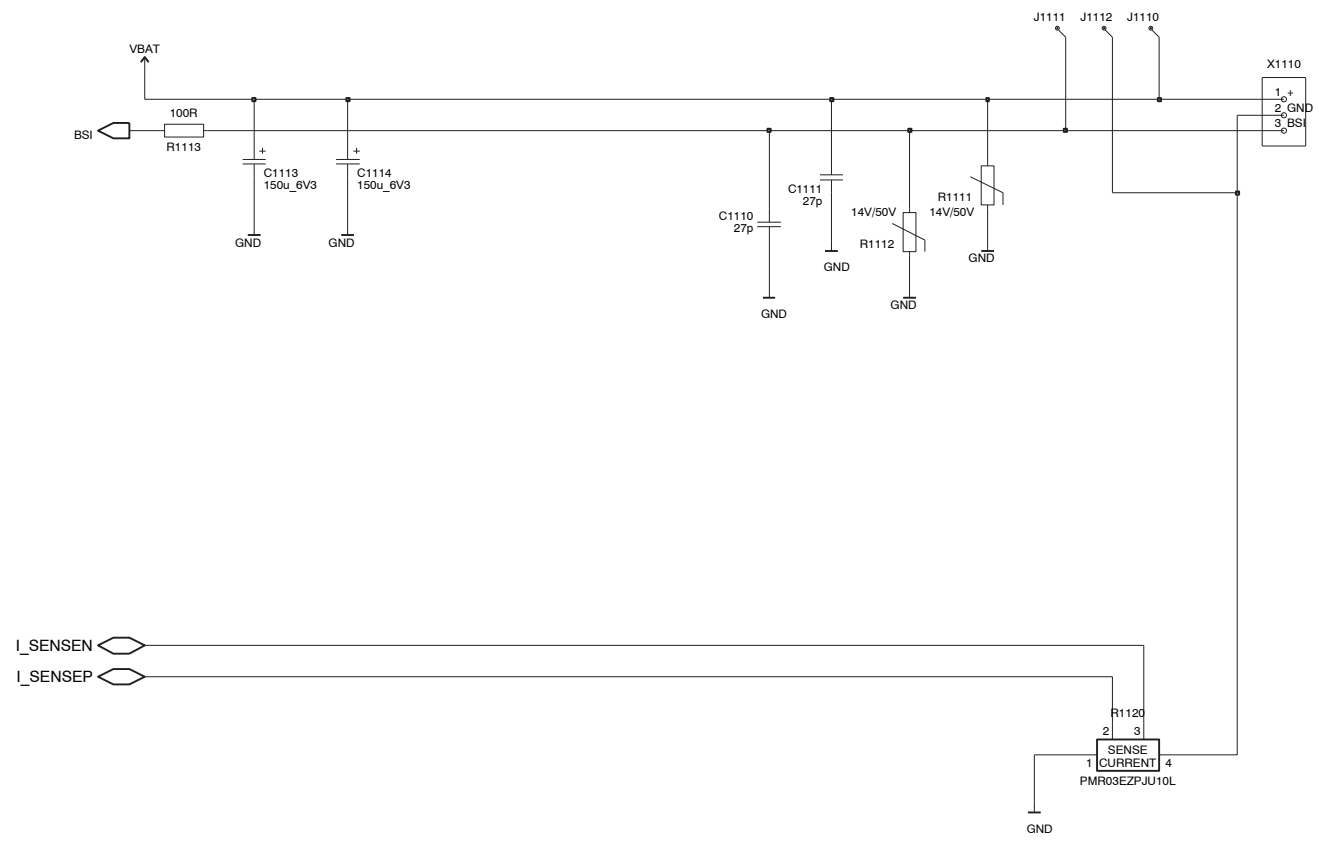
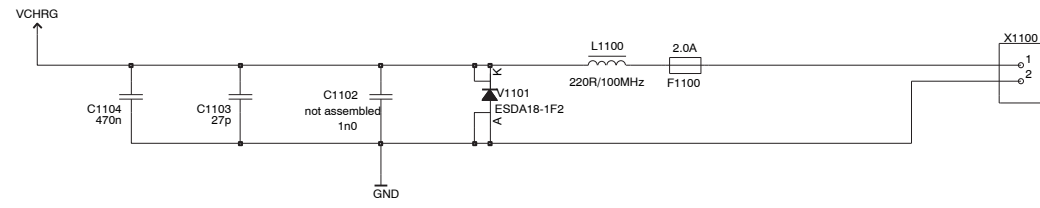

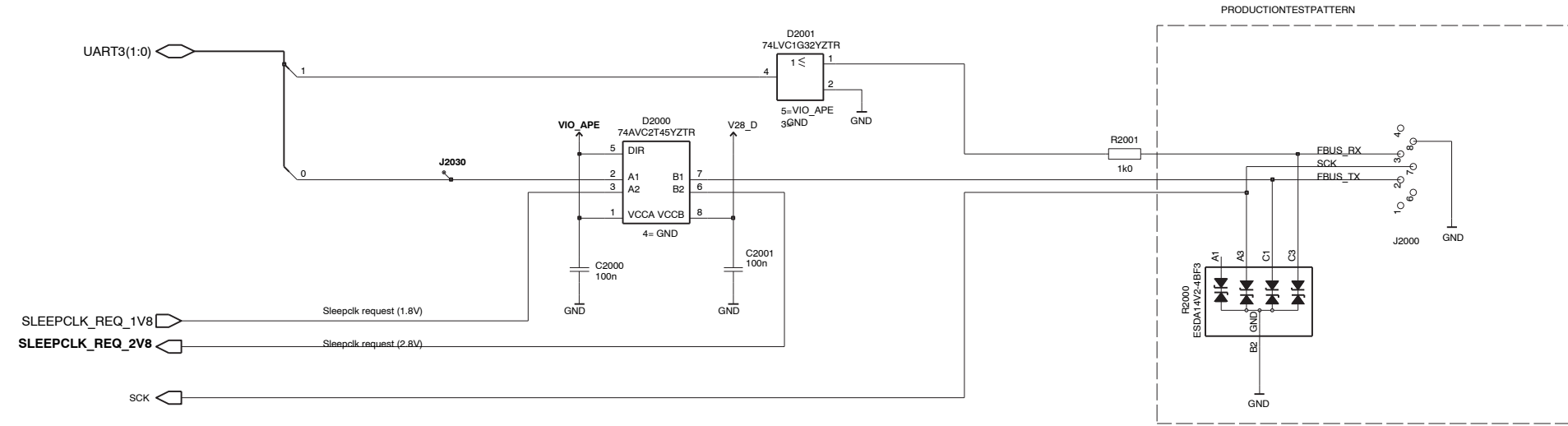
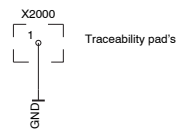

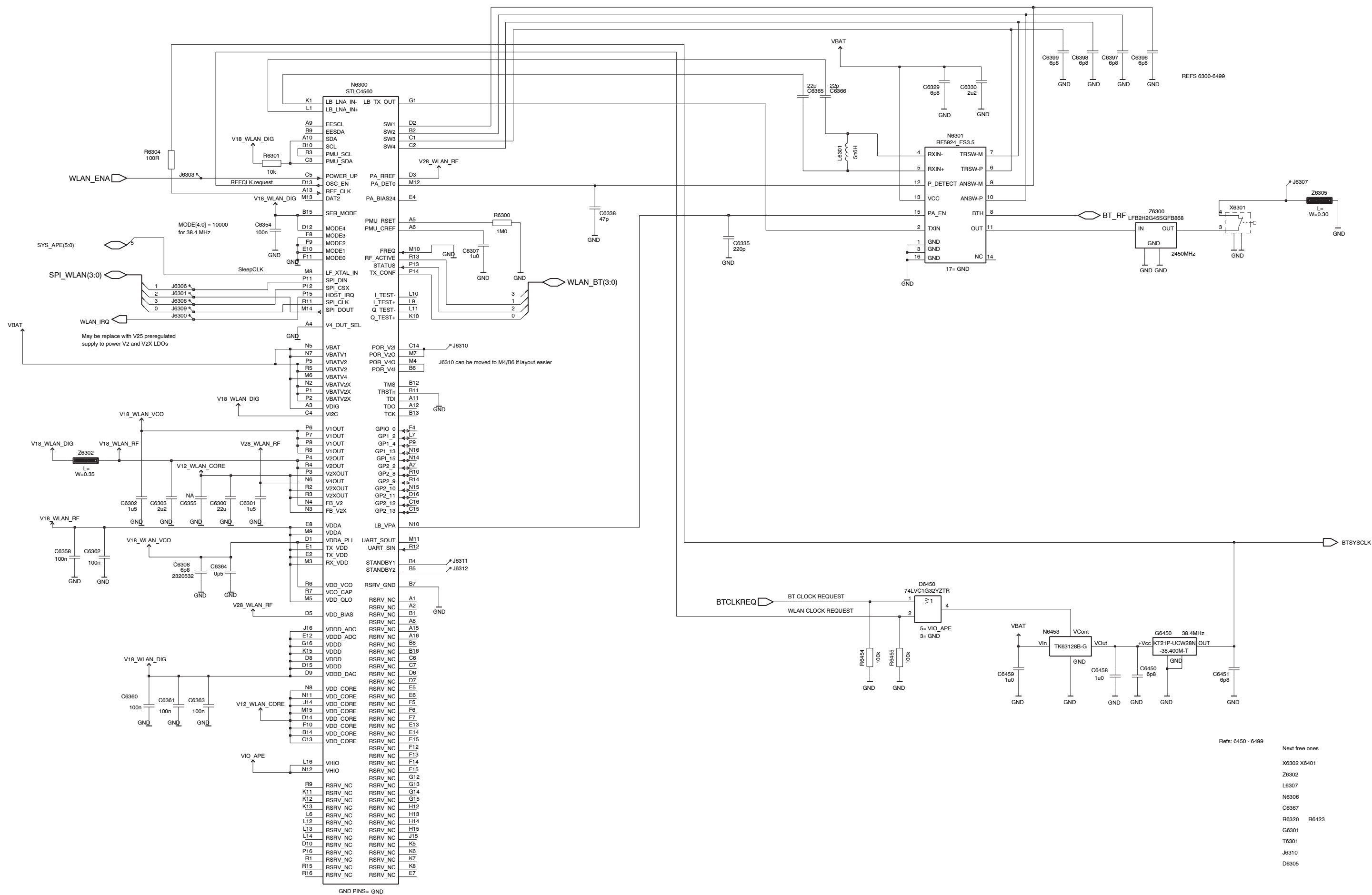

Refs: 6450 - 6499

Next free ones
X6302 X6401
Z6302
L6307
N6306
C6367
R6320 R6423
G6301
T6301
J6310
D6305

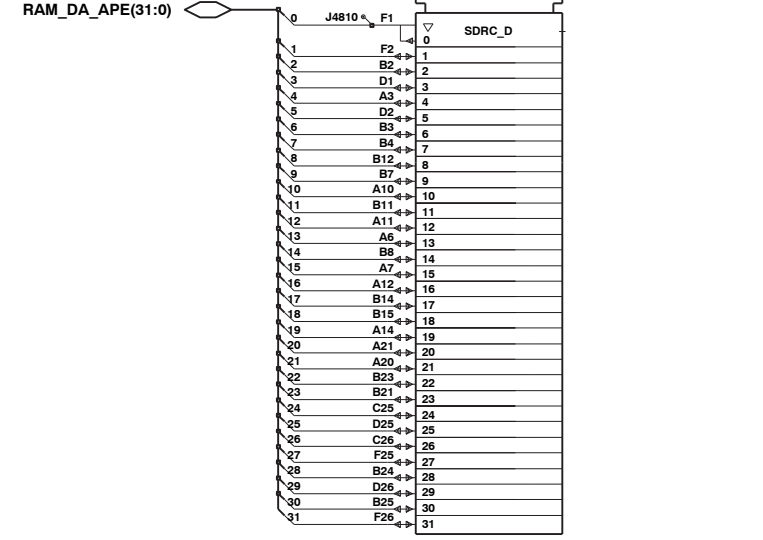
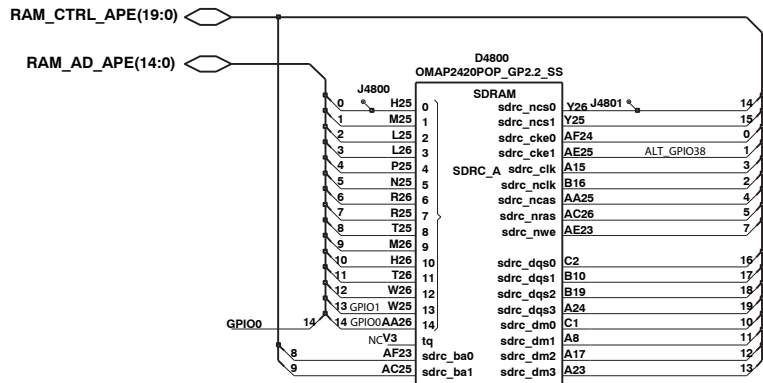

GPIO0	FS-USB Reset/HSUSB ENA	0
GPIO3	DMAREQ5 for HSUSB	3
GPIO4	DMAREQ4 for HSUSB	4
GPIO5	DMAREQ3 for HSUSB	5
GPIO6	DMAREQ2 for HSUSB	6
GPIO7	UNUSED GPIO7	7
GPIO9	VIO_SD enable	9
GPIO10	Headset PA enable	10
GPIO11	UNUSED GPIO11	11
GPIO13	DMAREQ1 for HSUSB	13
GPIO14	DMAREQ0 for HSUSB	14
GPIO23	VSD enable	23
GPIO24	RGB_CNTL_EN	24
GPIO27	RGB_CPNT_INT	27
GPIO33	UNUSED GPIO33	33
GPIO36	Boot mode selection	36
GPIO47	UNUSED GPIO47	47
GPIO58	HS/FSUSB INT	58
GPIO59	UNUSED GPIO59	59
GPIO63	POWEROK	63
GPIO68	UNUSED GPIO68	68
GPIO86	UNUSED GPIO86	86
GPIO96	MMC Slot select	96
BTHOSTWAKE		99
GPIO101	IHF PA enable	101
GPIO102	LOCK SW	102
GPIO109	SLEEPX LED CTRL	109
GPIO119	Boot mode selection	119
GPIO120	Boot mode selection	120
GPIO121	Boot mode selection	121
GPIO122	Boot mode selection	122
GPIO123	SMPS_CLK	123
GPIO124	Boot mode selection	124

AC23	tv_rref	dss_d0	Y9	BLU0/D0	0	
AD23	tv_cvbs	dss_d1	AC9	BLU1/D1	1	
AB26	tv_vref	dss_d2	AC8	BLU2/D2	2	
		dss_d3	AE9	BLU3/D3	3	
		dss_d4	AD9	BLU4/D4	4	
		dss_d5	AD10	BLU5/D5	5	
		dss_d6	W11	GRN0/D6	6	
		dss_d7	AC11	GRN1/D7	7	
		dss_d8	AD11	GRN2/D8	GPIO38	8
		dss_d9	AD12	GRN3/D9	GPIO39	9
		dss_d10	AC12	GRN4/D10	GPIO40	10
		dss_d11	AE11	GRN5/D11	GPIO41	11
		dss_d12	AE13	RED0/D12	GPIO42	12
		dss_d13	AD13	RED1/D13	GPIO43	13
		dss_d14	AC13	RED2/D14	GPIO44	14
		dss_d15	Y12	RED3/D15	GPIO45	15
		dss_d16	AD14	RED4/TEV50	GPIO46	20
		dss_d17	Y13	GPIO47	GPIO47	

LCD(21:0) connections to HS/CX, PCLK/RDX, DATA_EN/CMD, VS/CX/WRX, dss_hsync, dss_pclk, dss_acbias, dss_vsync, dss_d14, dss_d15, dss_d16, dss_d17, Y13, GPIO47, GPIO47.

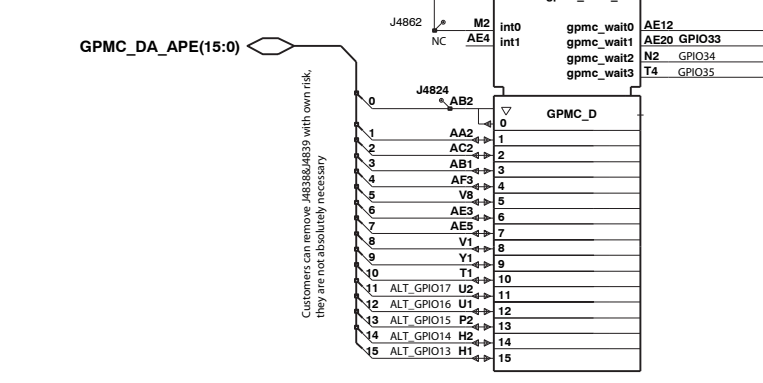
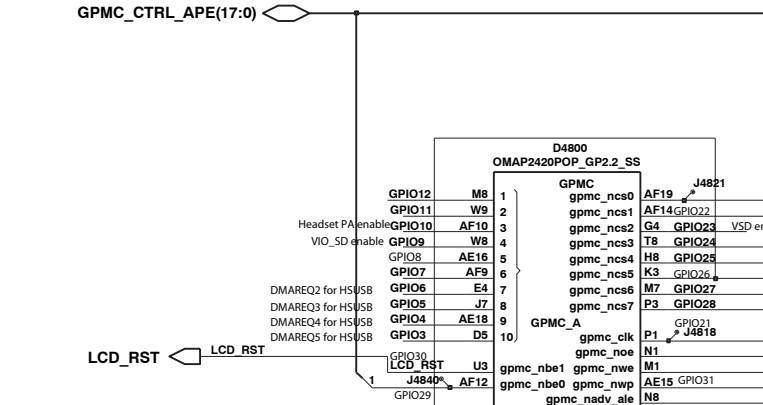

GPIO12	M8	1	gpmc_ncs0	AF19	J4821	0
GPIO11	W9	2	gpmc_ncs1	AF14	GPIO22	7
GPIO10	AF10	3	gpmc_ncs2	G4	GPIO23	8
GPIO9	W8	4	gpmc_ncs3	T8	GPIO24	9
GPIO8	AE16	5	gpmc_ncs4	H8	GPIO25	10
GPIO7	AF9	6	gpmc_ncs5	K3	GPIO26	11
GPIO6	E4	7	gpmc_ncs6	M7	GPIO27	12
GPIO5	J7	8	gpmc_ncs7	P3	GPIO28	13
GPIO4	AE18	9	gpmc_ncs8			
GPIO3	DS	10	gpmc_ncs9			
GPIO2		11	gpmc_ncs10			
GPIO1		12	gpmc_ncs11			
GPIO0		13	gpmc_ncs12			
GPIO30		14	gpmc_ncs13			
LCD_RST		15	gpmc_ncs14			
LCD_RST		16	gpmc_ncs15			
LCD_RST		17	gpmc_ncs16			
LCD_RST		18	gpmc_ncs17			
LCD_RST		19	gpmc_ncs18			
LCD_RST		20	gpmc_ncs19			
LCD_RST		21	gpmc_ncs20			
LCD_RST		22	gpmc_ncs21			
LCD_RST		23	gpmc_ncs22			
LCD_RST		24	gpmc_ncs23			
LCD_RST		25	gpmc_ncs24			
LCD_RST		26	gpmc_ncs25			
LCD_RST		27	gpmc_ncs26			
LCD_RST		28	gpmc_ncs27			
LCD_RST		29	gpmc_ncs28			
LCD_RST		30	gpmc_ncs29			
LCD_RST		31	gpmc_ncs30			

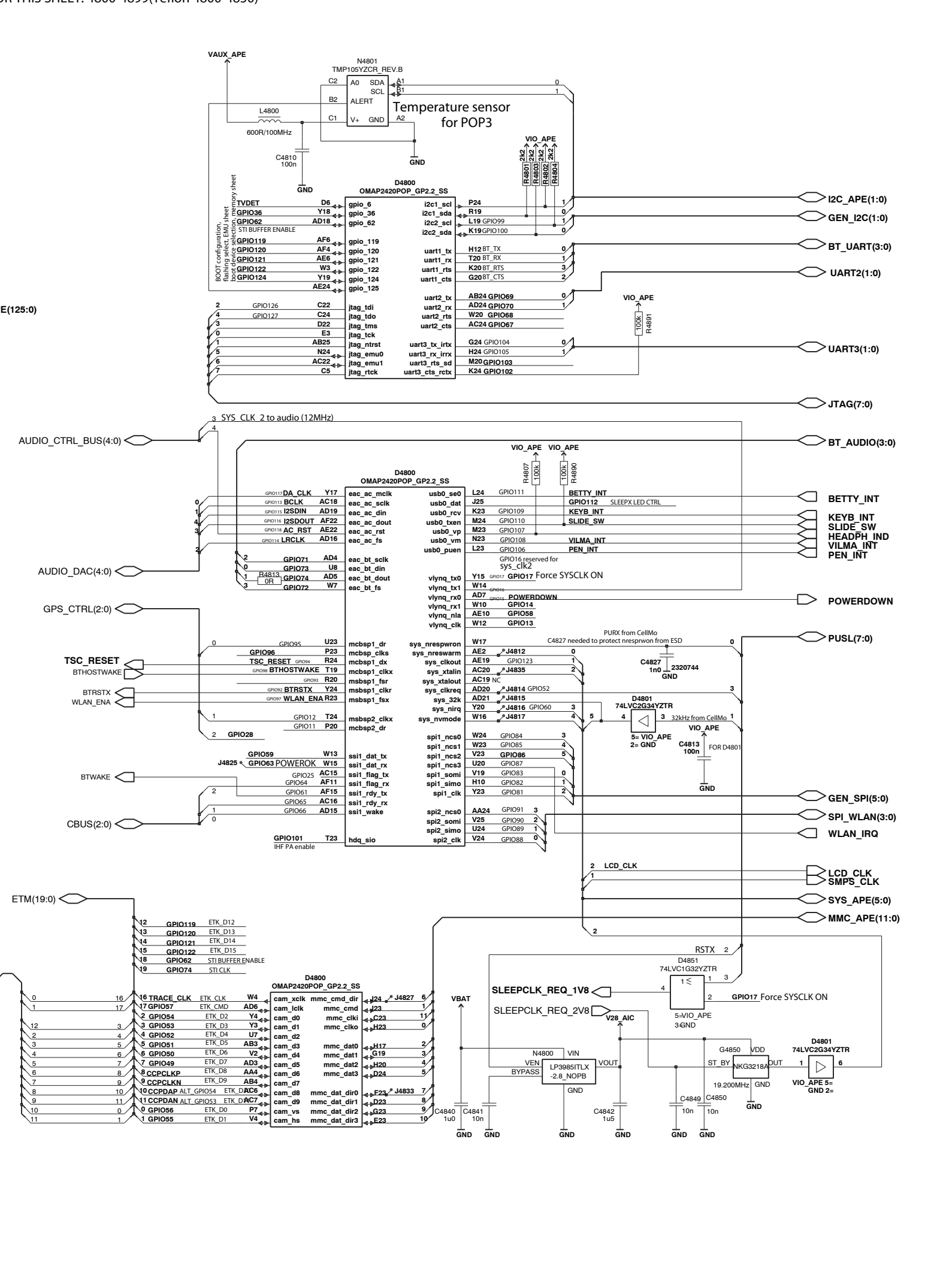
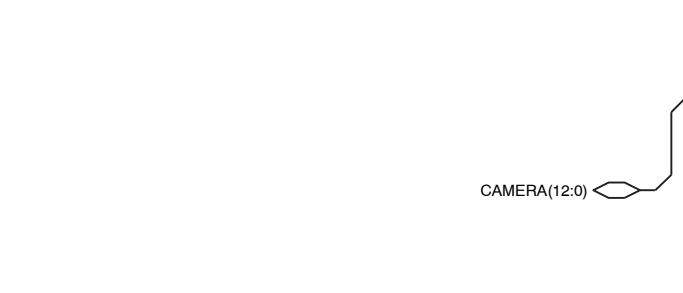

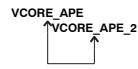

Capacitor places
 C4800: C15,D15,C16,D16,G14,H14,G15,H15
 C4801: M19,P19,U19,U26
 C4802: AD2,Y2,AA1
 C4803: Y8,AF7
 C4804: C14,C17,C18,D14,D17,D18
 C4806: C10,C11,D10,D11,D12
 C4807: G2,L1,L2,K2,K4,M4,N7
 C4808: N3,R7,T2
 C4814: F3,F4,G3,J1,J2,J3,J4,H3,H4
 C4816: F3,F4,G3,J1,J2,J3,J4,H3,H4
 C4817: L3,L4,M3,M4
 C4818: R1,R3,R4,T3,U4
 C4819: W1,AC1,AC5,W7,Y7
 C4820: E26,H19,J20,L20
 C4821: J26,N26
 C4822: V20,V26,AA23
 C4823: AF18
 C4824: C12
 C4825: E26,H19,J20,L20
 C4826: C15,C16,D15,D16,G14,G15,H14,H15
 C4828: A19,B20,C21,D21
 C4830: G26,K26
 C4832: AF21,AD26
 C4833: AC17,AE17,AF13,AF17,Y11,Y16
 C4834: B6,C8,D8,G8,H7
 C4835: A19,B20,C21,D21
 C4836: A19,B20,C21,D21
 C4838: AD26,AF21

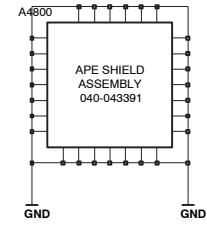
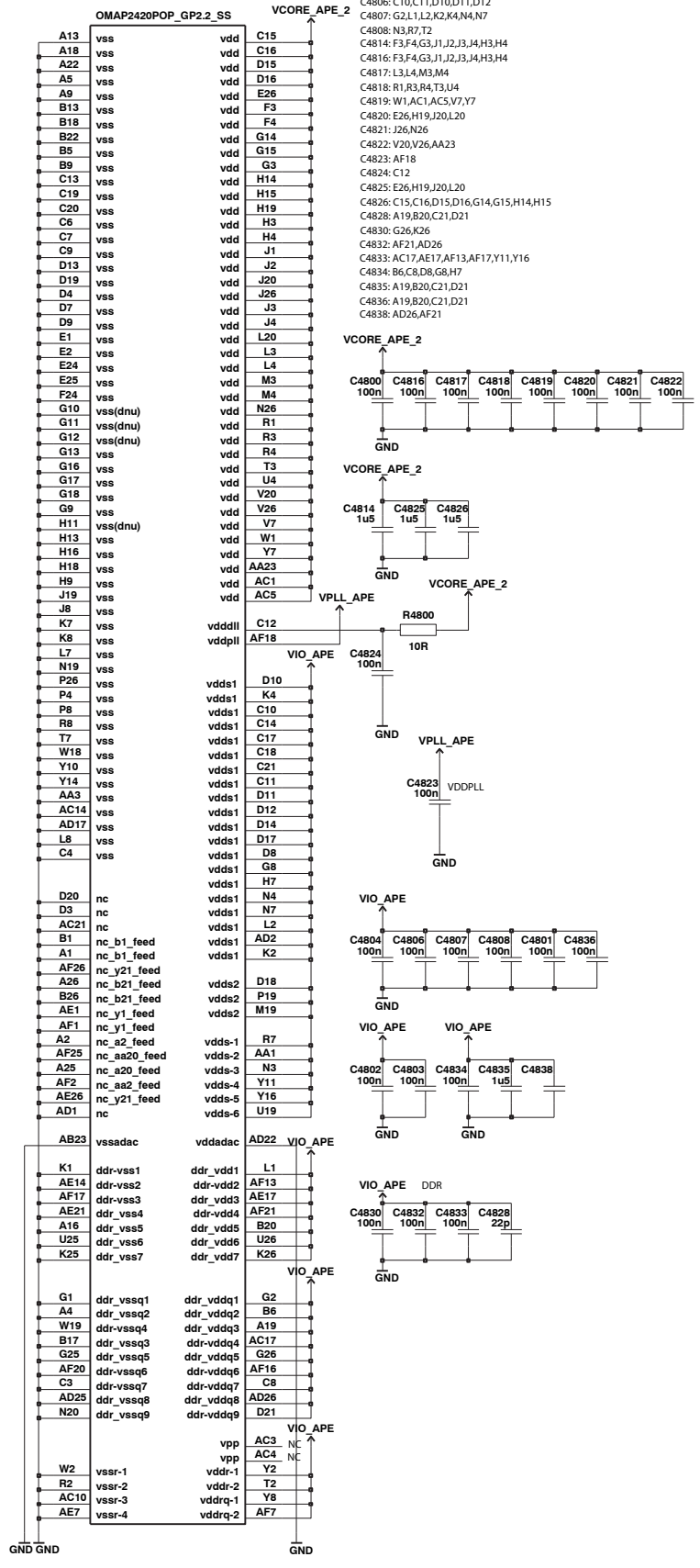

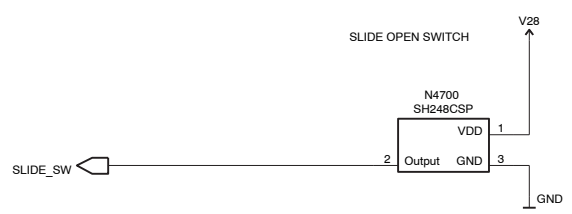
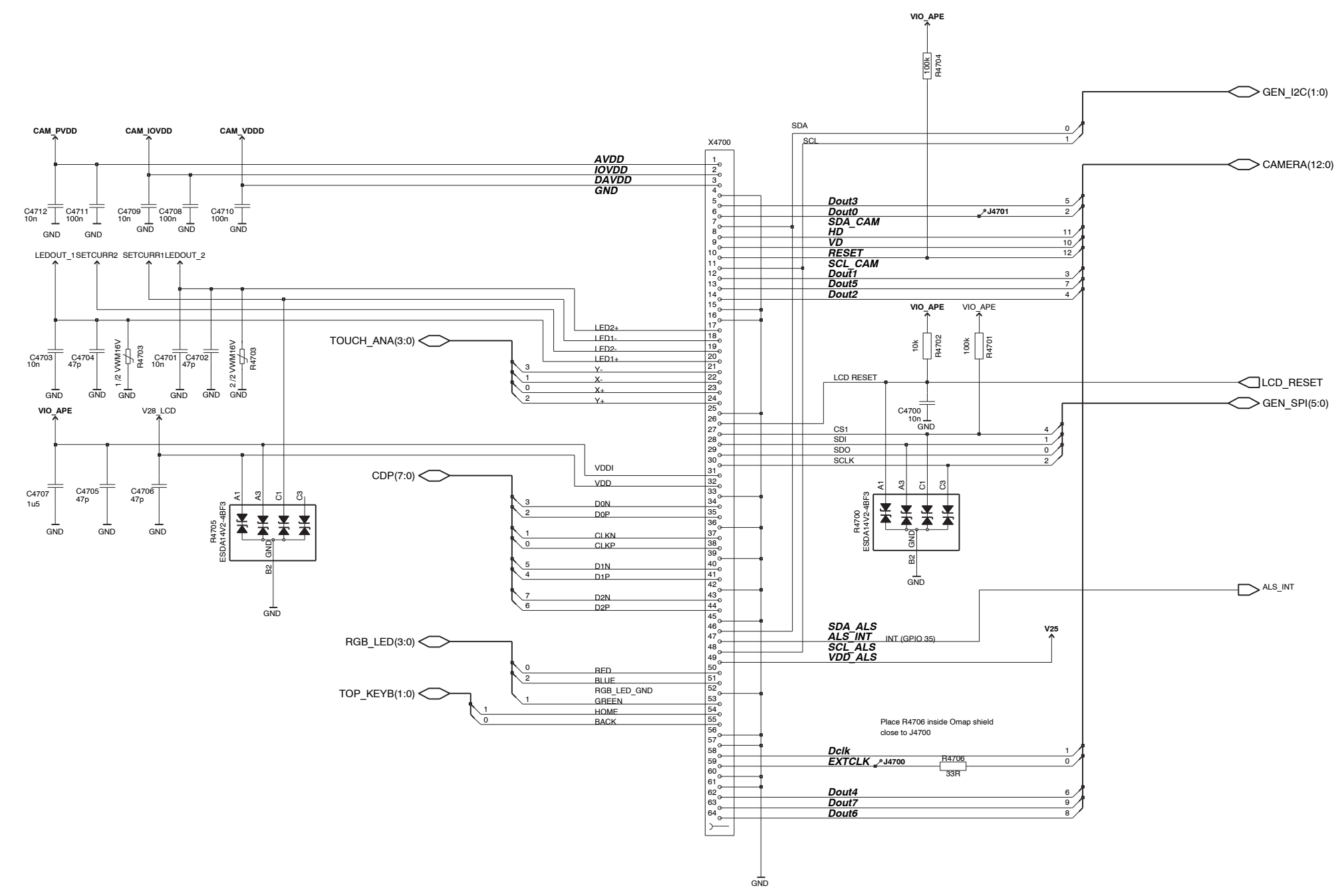

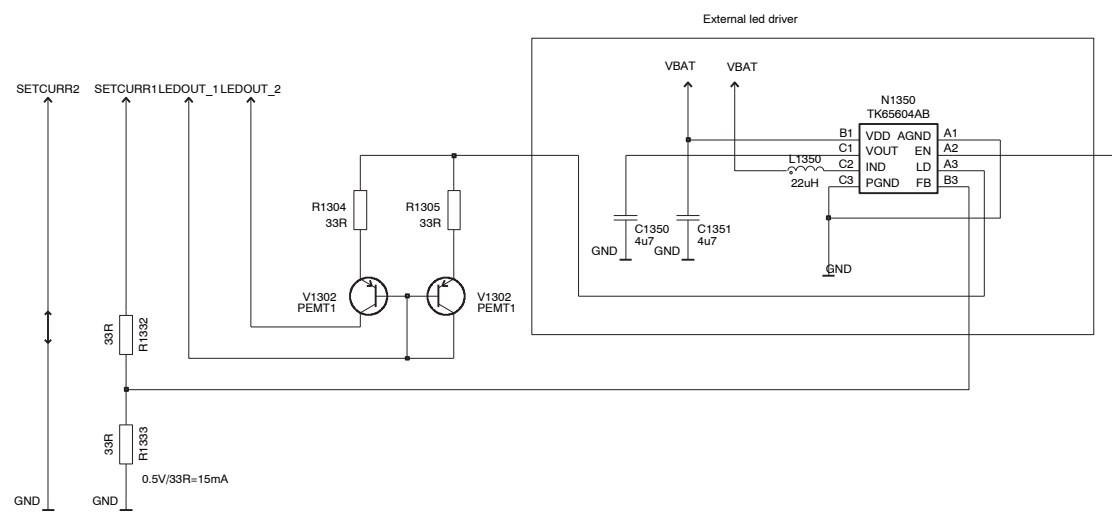
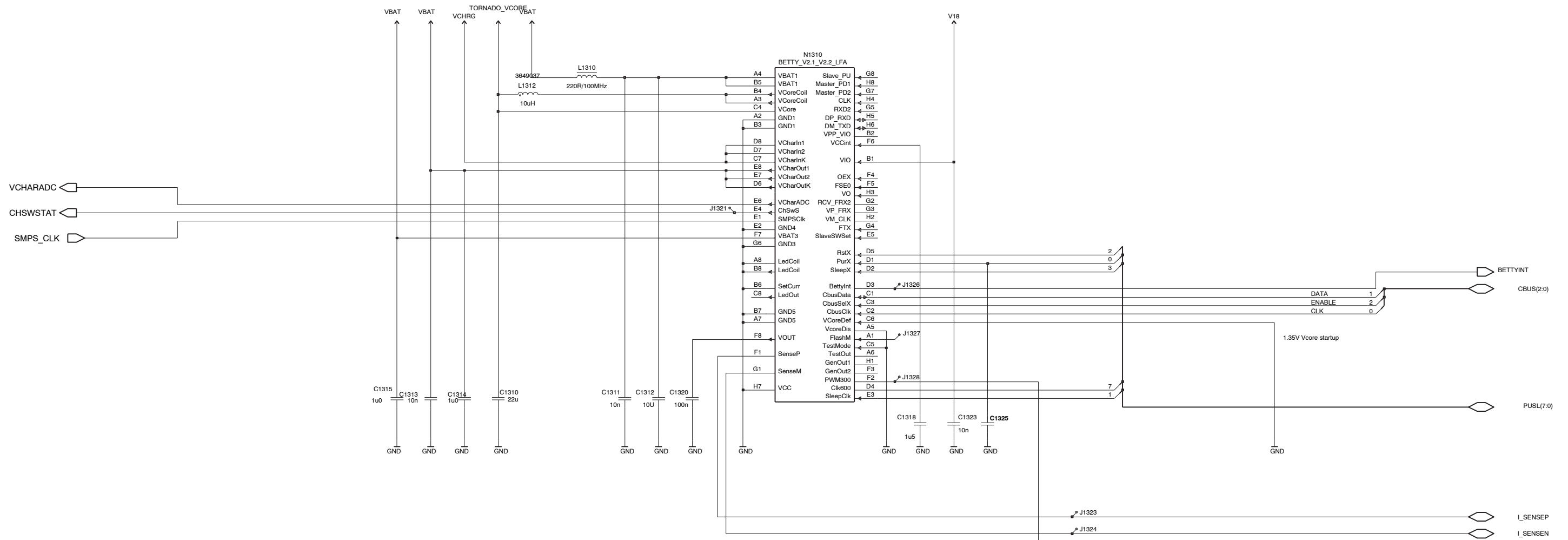

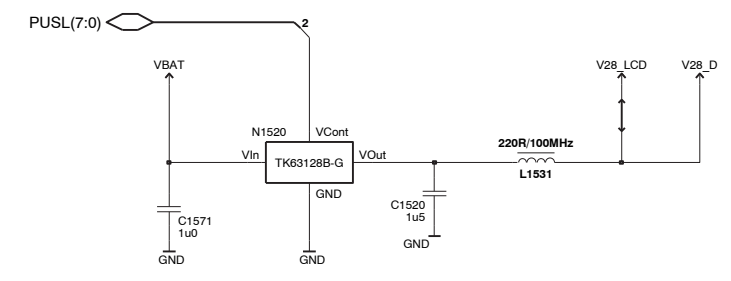
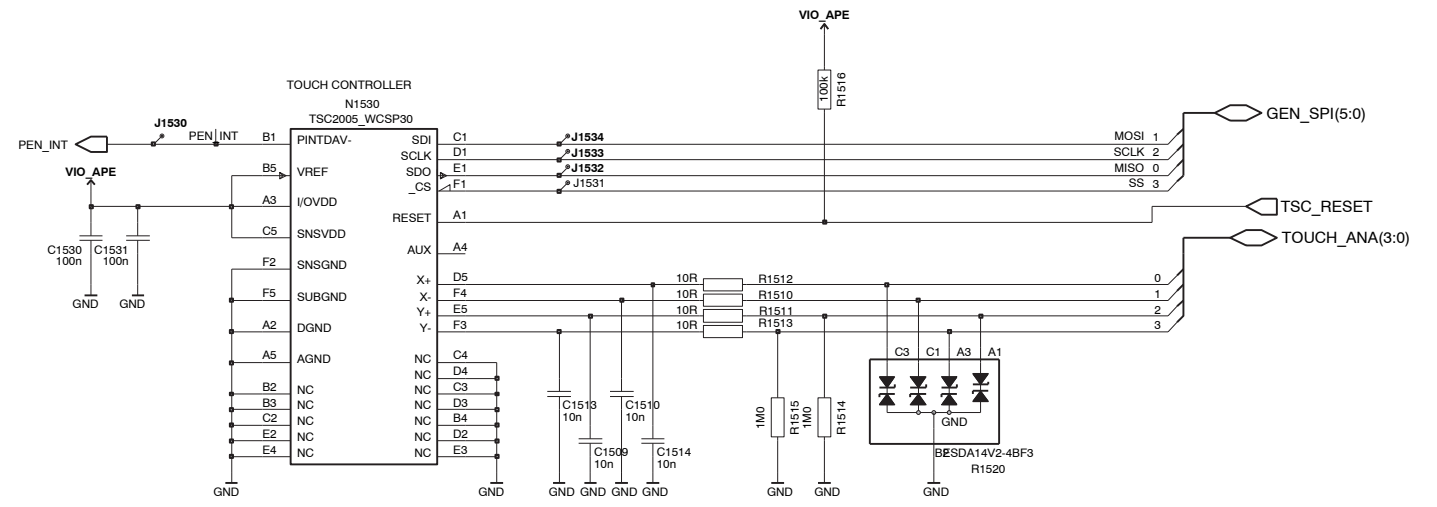
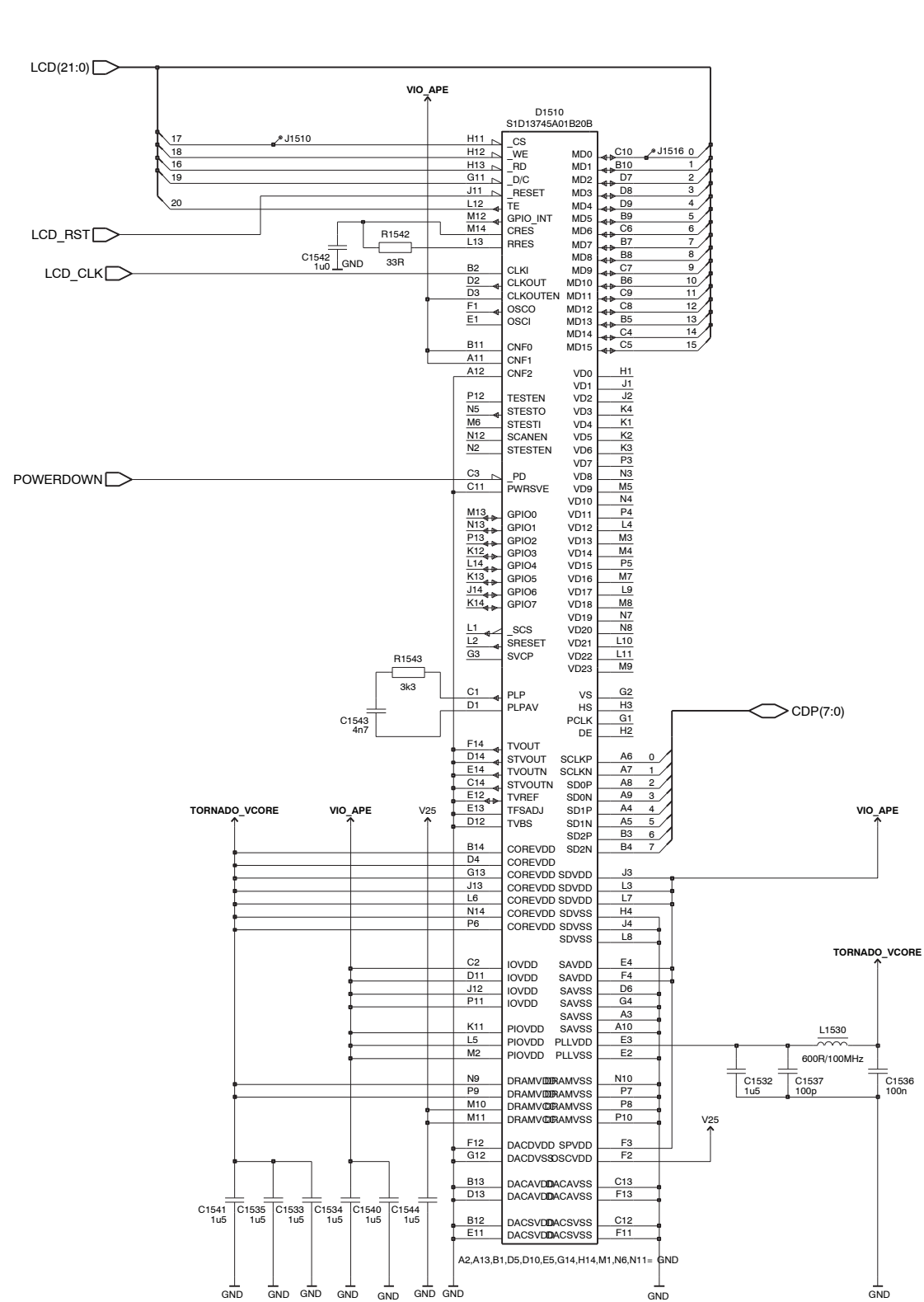

LOWER BLOCK GROUNDING

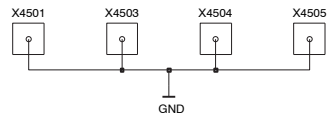

TOP BLOCK GROUNDING

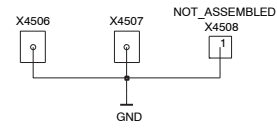

QWERTY US/UK

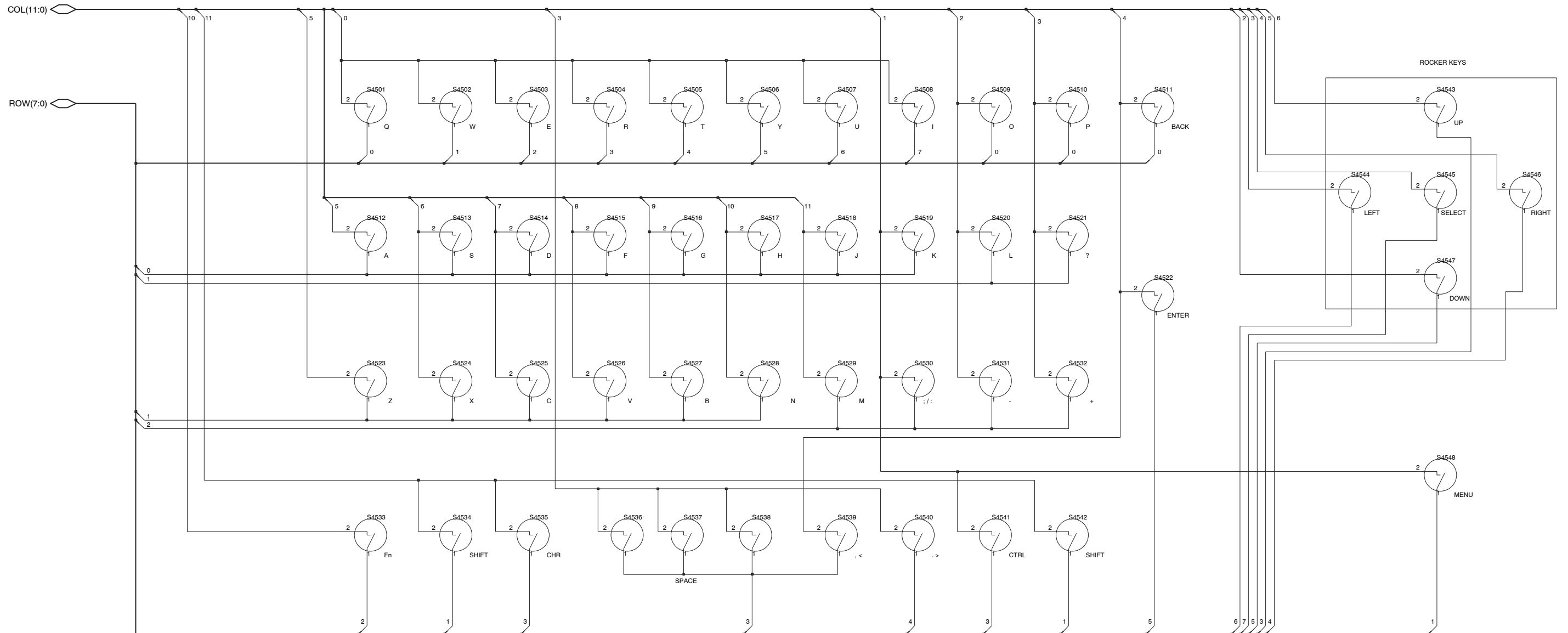

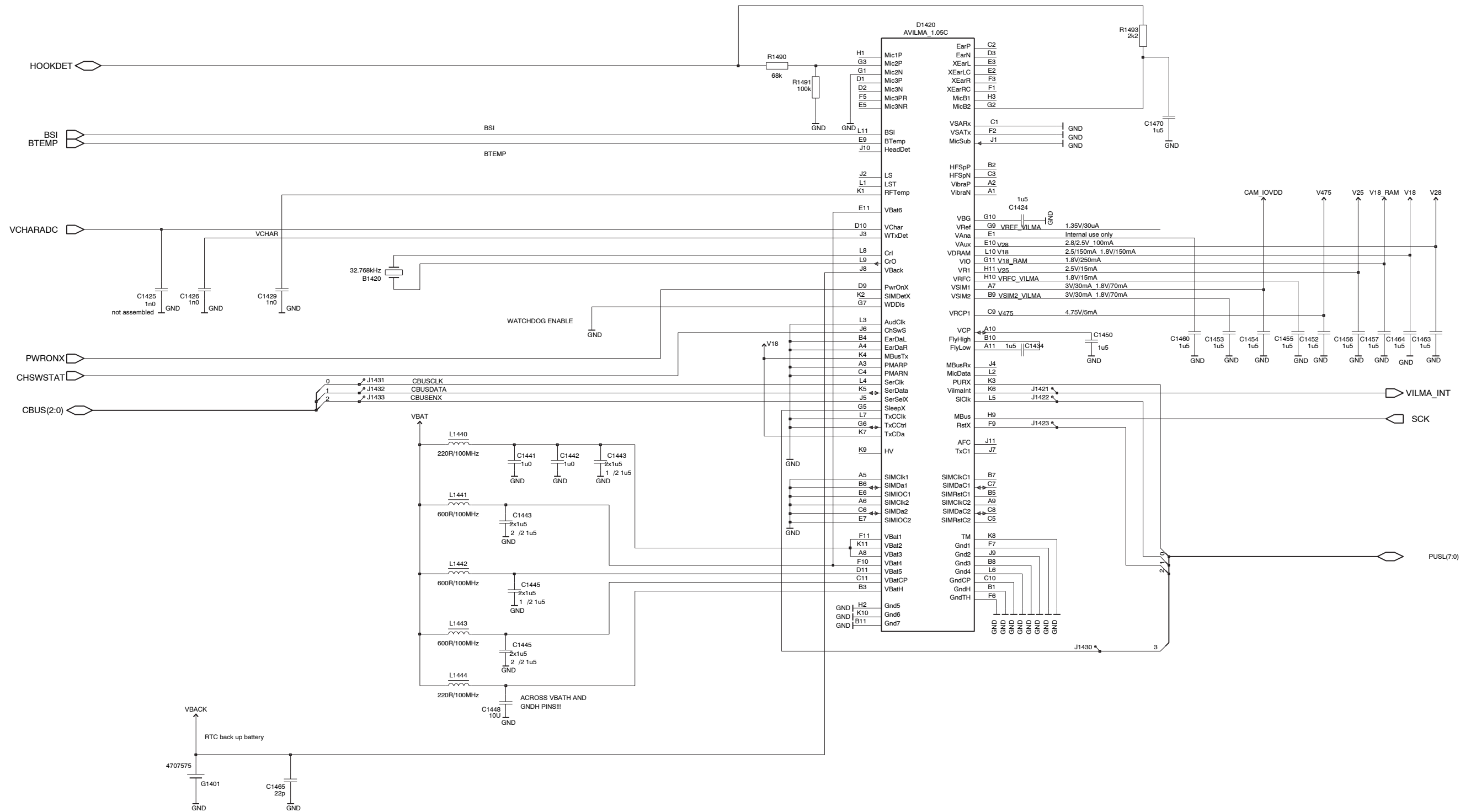

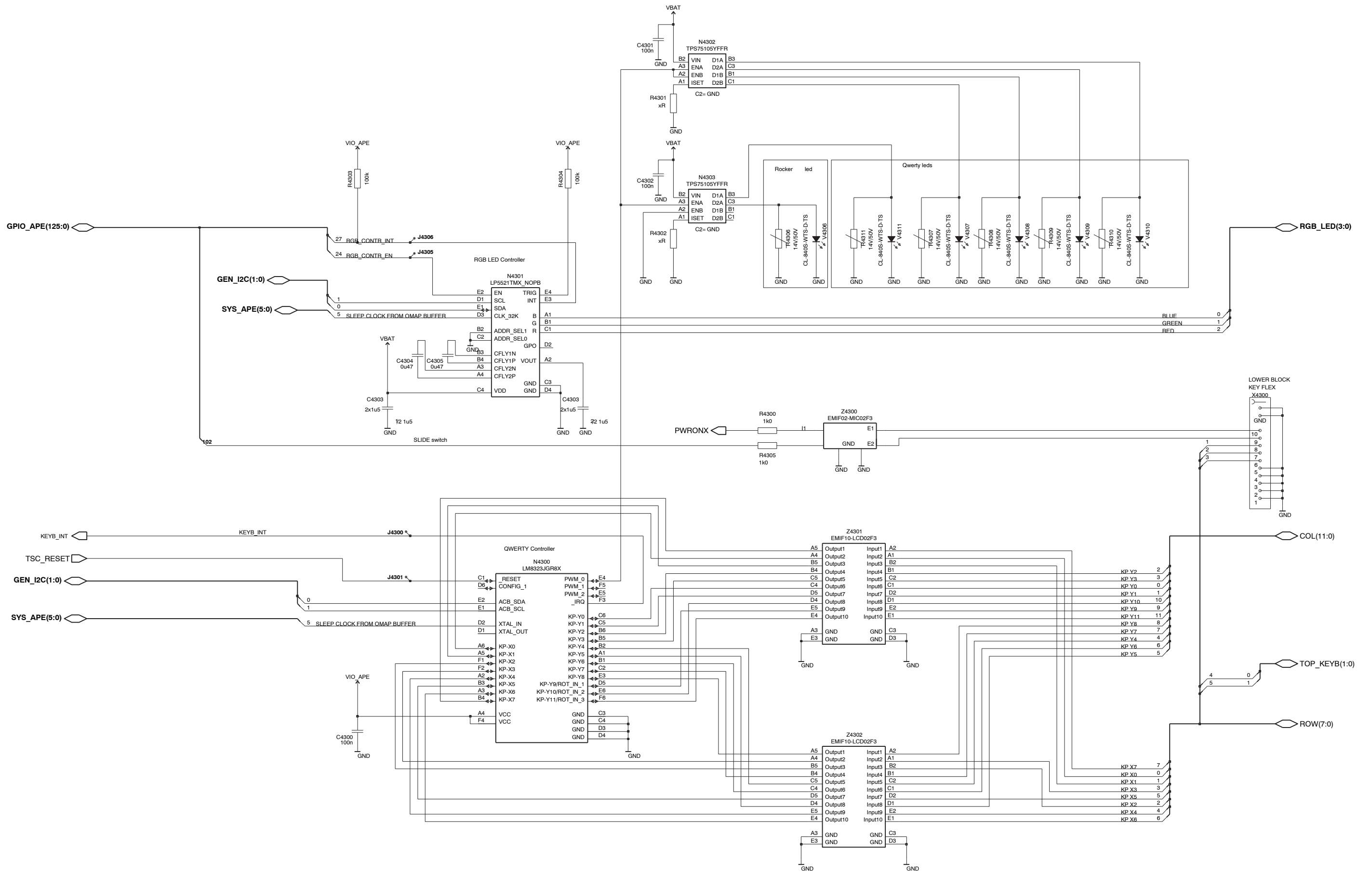

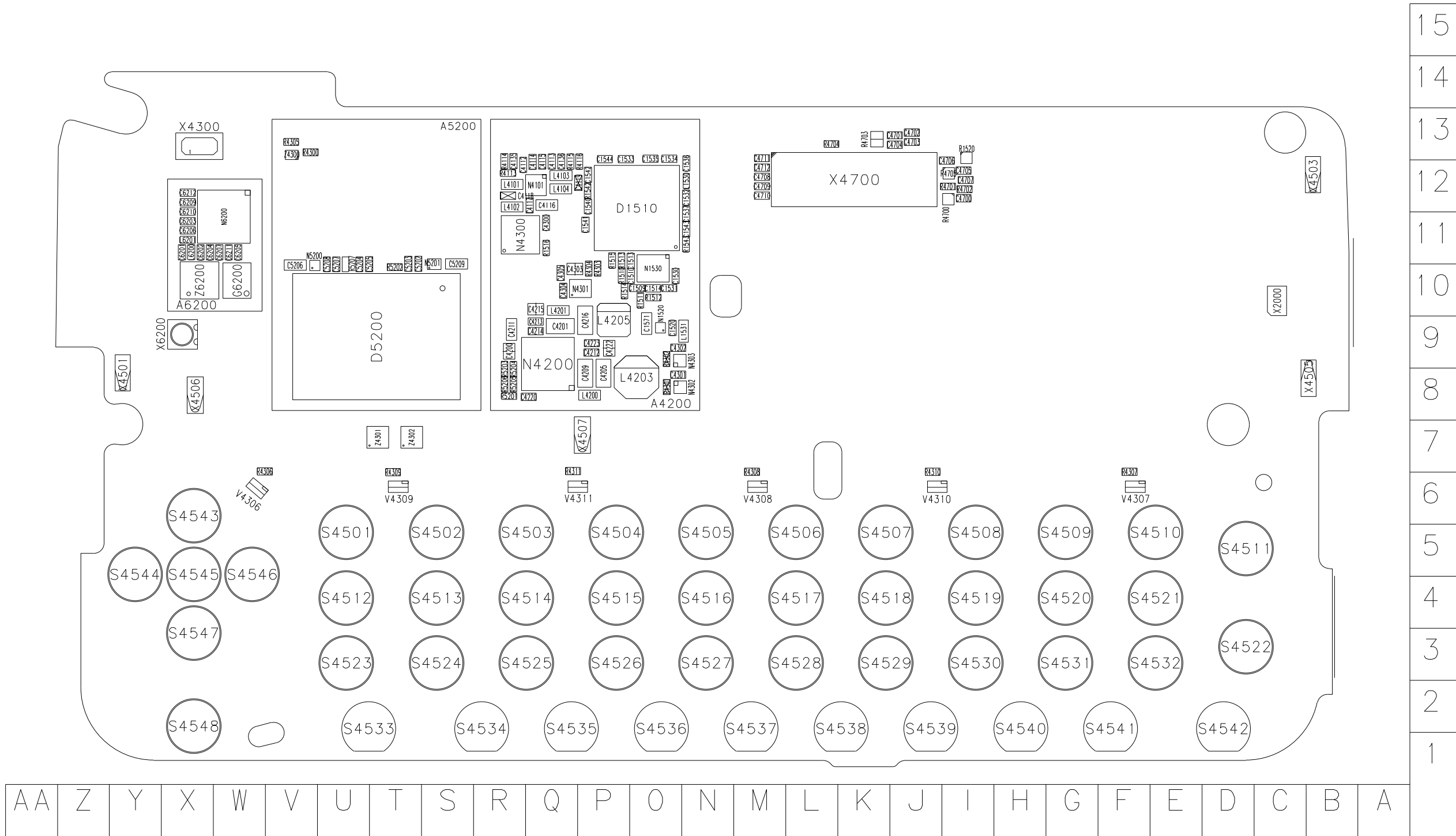

15
14
13
12
11
10
9
8
7
6
5
4
3
2
1

AA	Z	Y	X	W	V	U	T	S	R	Q	P	O	N	M	L	K	J	I	H	G	F	E	D	C	B	A
----	---	---	---	---	---	---	---	---	---	---	---	---	---	---	---	---	---	---	---	---	---	---	---	---	---	---

15
14
13
12
11
10
9
8
7
6
5
4
3
2
1

